

Play value

Stones are not mute. Being able to generate a sound from the oversized stones of the giant xylophone is a moving experience. Tapping the solid, heavy granite, marble or volcanic stone with a rubber beater produces a wealth of sounds and harmonies which has an exciting effect on people. Stonemasons recognise stones and their internal characteristics by their sound. Density, hardness and homogeneity of stones are shown during tapping by differing pitch and tonal quality.



Photo © Anton Donikov

The Stone Xylophones are created from specially chosen blocks of black granite. This ensures a high-quality sound and break-resistance.

Recommended for

- School children
- Young people
- Adults
- Supervised play areas such as schools, after school programmes or similar
- Public play areas without supervision such as playgrounds, parks or similar

Barrier-free

- Independent play

Acoustic effect	medium
Vandalism	not vulnerable
Supervision	not necessary
Explanation Board	recommended
Installation	indoors and outdoors
Safety check (DIN EN 1176)	not necessary
Installation in concrete	possible

Stone Xylophone
graubner Play Stations
 for Developing the Senses

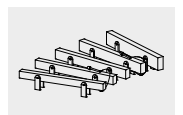

10.46000

Order No. 10.46000
Stone Xylophone

Safety distance →
 Device dimensions ●—
 Functional distance —|

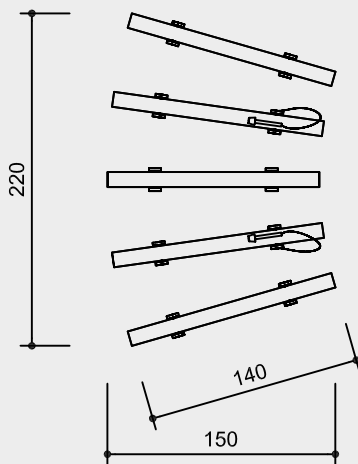

Scale 1:50

Technical information

Beater made of black synthetic material, suspension made of stainless steel cable

Ground anchor

All parts used for anchoring to the ground are made of hot-dip galvanised steel or stainless steel



For more detailed explanation of the quality characteristics see price list.

The selected granite stones must be very sturdy and yet produce a good sound. The stones are polished on all sides and tuned to each other.

Dimensions

(small deviations possible)

Height	0.30 m
Length	1.40 m
Width	2.20 m
Weight	490 kg

Components

5 Stones with supporting constructions for dowelling and 2 beaters, incl. 12 heavy duty anchors

Trademark

30 2005 500 000 Germany
 40-0682207 South Korea

Explanation board on request

Installation information

Recommended space
 4.00 x 3.00 m

Foundations

1 item 50 x 250 x 30 cm
 Excavation depth 40 cm
 1 item 40 x 200 x 30 cm
 Excavation depth 40 cm

Attention:

Exact measurements may vary; for all installation dimensions refer to current assembly instructions.

Technical changes reserved.

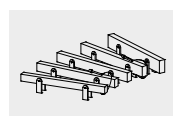

10.46000