

Instructions for wear checks of play equipment

The equipment must be checked for correct operation and safety, especially the points listed below:

Proof of maintenance

Playground.....

Date of installation

Checks depend on the type of equipment. Any equipment with moving parts must be checked at least twice a year, static equipment at least once a year.

Intervals for maintenance work and checks generally depend on

- the location
- the usage
- the frequency of use
- possible vandalism

For more details see also "General instructions for maintenance of playgrounds".

Mobile Water Playground
rectangular
Order No. 5.21800

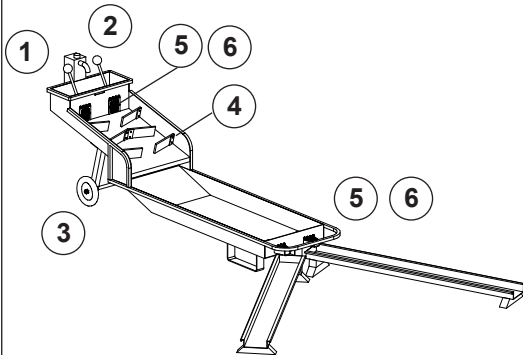

Water dispenser

1. Check that the handle moves smoothly.
2. Check water flow and rinse supply line if necessary.

Chassis

3. Check that rubber tyres are in proper condition and move smoothly, replace tyres if necessary.

Flow obstacles

4. Check that obstacles are in proper condition and move smoothly.

Flaps

5. Check that flaps are in proper condition and move smoothly, replace rubber parts if necessary.
6. Check that strainers are not clogged, clean if necessary.

Special notes, e.g. for repairs

Repair not carried out, it is still possible to play on equipment

Repair not carried out, equipment is taken out of action

All work carried out, everything is in order

Maintenance carried out by:

..... Date