

**Play value**

Our Fire Engine brings smiles to the faces of children young and old – even from afar. Imaginative role play knows no limits here. The driver's cab offers space for three children side by side: one at the rotating steering wheel while the other two get ready for action. A special highlight is the foot pump integrated into the cab, which powers the swivelling spraying head that actually shoots water when the pedals are pressed. Two benches on the rear platform provide additional seating for more young – and not so young – firefighters.



The photos show our prototype. Technical changes reserved.

**Fire Engine with Spraying Head**

**Fundamental characteristics**

- Friendly appearance
- Child-friendly dimensions
- Emotionally evocative design
- Natural wooden surfaces for tactile sensory appeal
- Play impulse: role-playing game
- Movement: climbing, exploring by touch
- Coloured design, Eye-catcher

**Recommended for**

- School children
- Supervised play areas, such as kindergartens, schools, after-school programmes or similar
- Public play areas without supervision, such as playgrounds, parks or similar
- Private play areas without supervision, such as campsites or similar

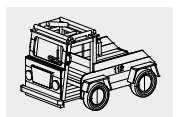

7.79300

**Order No. 7.79300**  
**Fire Engine with Spraying Head**

Safety distance →  
 Device dimensions —●—  
 Functional distance —|—

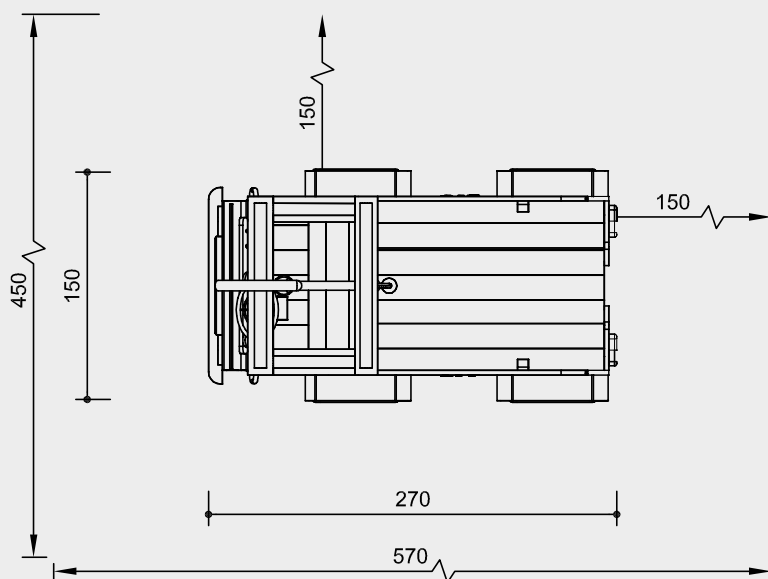
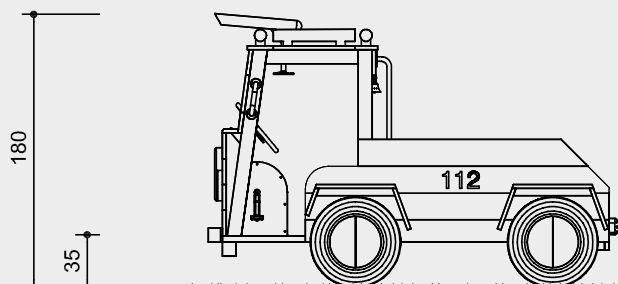

Scale 1:50

Safety check according to DIN EN 1176

**Components**

- 1 Fire Engine with 5 steel feet
- 1 Spraying Head, rotatable, spray angle 45°
- 1 Pedal Pump

**Installation information**

Surfacing requirements corresponding to a fall height of ≤ 1.00 m (please refer to price list for more detailed information)

Foundations  
 2 items 60 x 120 x 50 cm  
 Excavation depth 70 cm  
 1 item 30 x 30 x 30 cm  
 Excavation depth 50 cm

**Attention:**  
**Exact measurements may vary;**  
**for all installation dimensions refer**  
**to current assembly instructions.**  
 Technical changes reserved.

**Technical information**

Play equipment built from natural mountain larch

**Core-free**

Sawn-timbers core-free, thus decreasing occurrences of cracking and undesired changes in shape



**Tongue and groove**

Tongue and groove planks made of 4 cm solid wood, highly resilient, no trickling of dust / sand, protection against direct rain



**Plywood**

Plywood made of mountain larch, thickness ≥ 3 cm. High dimensional stability. Weatherproof glued according to DIN EN 13353:2011



**Profiled washer**

Profiled washer for covering protruding screw heads according to standard, improved pressure distribution and protection against water. Impedes loosening the bolt



**Ground anchor**

All parts used for anchoring to the ground are made of hot-dip galvanised steel or stainless steel



**For more detailed explanation of the quality characteristics see price list.**

**Colour**

Solvent-free acrylic paints are used for colouring; the wood is painted in a way which allows the structure of the wood to remain clearly visible

Bell made of brass

Grips and Steering wheel made of stainless steel, glass bead blasted

Realistic tyre replica

Spraying head made of stainless steel (V2A), with pivoting hand wheel, double-sided stop, glass-bead blasted

**Planning information**

The pedal pump can pump self-priming from a water reservoir provided by the customer; maximum suction height 2.5 m. Alternatively **Order No. 5.17100** Valve combination can be used.

**Dimensions**

(small deviations possible)

Height	1.80 m
Length	2.70 m
Width	1.50 m
Weight	approx. 430 kg

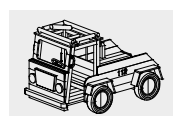

7.79300